

THERMAL ANALYSIS OF A RCC DAM DURING CONSTRUCTION

7th ICOLD Benchmark Workshop on
Numerical Analysis of Dams

Bucarest (Romania), 24 - 26 September 2003

by Eng. Francesco Amberg

THERMAL ANALYSIS OF A RCC DAM DURING CONSTRUCTION *

Francesco Amberg
Lombardi Engineering Ltd., SWITZERLAND

SUMMARY: The paper presents a study carried out to evaluate the thermal behavior of a 92 m high RCC dam during construction. This calculation exercise was proposed in the frame of the 7th Benchmark Workshop on Numerical Analysis of Dams organized by the ICOLD, with the aim to provide a critical examination of the computational methods used for dam analyses.

The simulation considers in a very detailed manner the conditions on a dam site, as the concreting schedule, the curing and protection of the surfaces, the development of the hydration heat; this obviously in relation to the environmental conditions, i.e. the air and water temperature, the solar radiation and the reservoir level. The analysis was carried out in a 2-D section of the dam body using a software developed by Lombardi Ltd. to analyze this type of problems. The software, based on the explicit Finite Difference Method, has already been used in a number of thermal analyses [see 1] with the purpose to define and optimize the cooling process for dams or to evaluate the thermally induced stresses and deformations.

RÉSUMÉ: L'article présente une vérification du comportement thermique d'un barrage poids en BCR de 92 m de hauteur. L'exercice de calcul a été proposé dans le cadre du 7^{ème} *Benchmark Workshop* en Analyse Numérique des Barrages organisé par la CIGB, dont le but est la comparaison et l'évaluation des méthodes numériques utilisées pour l'analyse des barrages.

Toutes les conditions qui peuvent se présenter au cours de la vie du barrage sont prises en compte dans l'analyse: ainsi le programme de bétonnage, le curage et la protection des surfaces, le développement de la chaleur d'hydratation, etc. tout en considérant naturellement les conditions de l'environnement, c'est-à-dire la température de l'air et de l'eau, l'ensoleillement et le niveau du réservoir. L'analyse a été conduite en une section bi-dimensionnelle du barrage en utilisant un logiciel développé spécifiquement par le bureau d'études Lombardi SA pour ce type d'analyses. Le logiciel, basé sur la méthode de calcul des différences finies explicites, a été employé pour l'analyse thermique de plusieurs barrages [voir 1], en particulier dans le but de définir et

* Analyse thermique d'un barrage BCR pendant la construction.

d'optimiser les systèmes de refroidissement artificiel du béton et d'évaluer les contraintes et déformations d'origine thermique.

1. INTRODUCTION

The 7th Benchmark Workshop on Numerical Analysis of Dams deals with the analysis of the thermal behavior of a RCC dam during construction. The 92 m high dam, which name and location hasn't been disclosed by the formulator of the problem, is apparently one of the largest RCC gravity dams presently under construction, with a total volume of several millions of cubic meters. The dam is located in a region with tropical climate.

The exercise consists in the prediction of the temperatures at different points. The calculated values will finally be compared with measurements done in the dam in order to evaluate the accuracy of the results and thus that of the computational methods used.

At the time of the problem formulation the construction of the dam had already reached a little more than half of the total height. Thus the real back analysis is limited to this first period. For that purpose, a 2-D or a 1-D analysis could be carried out, considering that in the short time most of the hydration heat will flow vertically to the upper dam surface. The analyses presented perform also a long term prediction, for which a 2-D analysis is clearly required. The first part of the construction program given corresponds exactly to the reality while the second part is a prospective schedule to complete the construction of the dam.

2. THEORETICAL BACKGROUND

2.1 BASIC EQUATIONS FOR HEAT TRANSFER WITHIN THE DAM BODY

The heat transmission in a body is taken into account by a linear function of the temperature gradient according to the well-known Fourier's Law:

$$q_x = -\lambda \cdot \frac{\partial T}{\partial x} \quad (1)$$

q_x being the heat flow in x direction and λ the thermal conductivity. At any time step the temperature changes are obtained from the heat balance considering the heat generated inside the concrete and the heat flow exchanged with the nearby elements:

$$\gamma \cdot c \cdot \frac{\partial T}{\partial t} = E_{\text{Idrat}} - \frac{\partial q_x}{\partial x} - \frac{\partial q_y}{\partial y} - \frac{\partial q_z}{\partial z} \quad (2)$$

where the rate of hydration heat E_{Idrat} is given in W/m^3 and represents the development of energy inside the concrete body; γ being the density and c the specific heat.

2.2 HEAT TRANSMISSION AT SURFACES

2.2.1 Convection and thermal radiation

At the surfaces, the transmission of heat to the environment is given by the following linear relationship:

$$q_{Air} = \frac{1}{R} \cdot (T - T_{Air}) \quad (3)$$

in which T and T_{Air} are the surface and the air temperature respectively while R is the thermal resistance, defined for general conditions as follows:

$$R = \sum \frac{1}{\alpha} + \sum \frac{d}{\lambda} \quad (4)$$

with α = interface transmission coefficient
 λ, d = thermal conductivity and thickness of the formwork or an insulating layer.

If a direct contact between concrete and air does occur, the convection coefficient may vary between 15 and 45 W/°C/m² depending primarily on the wind velocity. The direct contact between concrete and water corresponds instead to a very high convectivity, so that the surface temperature can be assumed at any time to equal the one of the water.

For thick dams, if no insulation is considered, the thermal resistance at the surface is of secondary importance, due to the fact that the thermal resistance would correspond roughly to an *over thickness* of concrete of only 5-10 cm.

2.2.2 Solar radiation

The solar radiation must be taken into account as it represents a significant amount of energy. The energy flow absorbed by the surface can be defined in the following form:

$$q_{Sun} = E_{Rad} \cdot c_{Abs} \cdot \cos \beta \quad (5)$$

where, E_{Rad} = actual radiation intensity at the dam face, calculated as the basic radiation of 1 kW/m² reduced according to the atmospheric conditions
 c_{Abs} = absorptivity of the concrete surface (0.50-0.65)
 β = angle between the sun and the outward normal of the face.

The energy flow is updated at every calculation step according to the actual position of the sun.

The solar radiation can be also taken into account in a simplified way in assuming an equivalent increase of the air temperature variable between 2 and 4°C (sometimes until 6°) depending of the site and the orientation of the surface.

2.2.3 Evaporation of water on surfaces

The computational code used takes into account also the effect of the curing of both the upper surface and the lateral faces. The specific energy flow q_{Evap} due to the evaporation of water on the surfaces depends directly from the rate of water evaporated w and is defined by the following linear relationship:

$$q_{Evap} = c_{Evap} \cdot w \quad (6)$$

where c_{Evap} is the specific evaporation heat, which was assumed to be 2'255 kJ/kg. The rate w of evaporating water in kg/h/m² can be estimated by: [see 2]:

$$w = (25 + 19 \cdot v) \cdot (x'' - x) \quad (7)$$

in which v is the wind velocity in m/s, x the absolute humidity of the air in kg/kg and x'' the saturation humidity at the temperature T , in °C, of the concrete face. Said saturation humidity is defined by the following equation:

$$x'' = (4.2 + 0.25 \cdot T + 0.0125 \cdot T^2 + 0.00028 \cdot T^3) \cdot 10^{-3} \quad (8)$$

The curing can play a very important role in the energy balance. Assuming a temperature of 30°C for the air and the concrete surface, a relative humidity of 70% and a wind velocity of 1 m/s, the specific energy flow corresponds to about 250 W/m² by an evaporating water mass of 0.4 l/h/m². The total energy dissipation by evaporation corresponds thus to 21.8 MJ/m² per day (24 h), which is nearly the double of the total hydration heat produced during the first day by a 1 m³ of RCC concrete.

2.3 COMPUTATIONAL METHOD USED

The transient heat balance in the dam body was simulated using a specific software developed by Lombardi Ltd., which performs pseudo-three-dimensional thermal analyses. The effective calculation of temperatures, deformations and stresses is carried out in a two-dimensional model, which takes into account the heat losses or gains of the lateral faces when the block under calculation has a higher elevation as the adjacent ones. Indeed, the software was especially developed to analyze and optimize the artificial post-cooling for usual concrete dams. This procedure is simulated in a very accurate way by taking into account many of the factors and parameters affecting the cooling. This aspect is no further discussed in the present paper because it is not included in the analysis presented hereafter.

The computation is based on the explicit Finite Difference Method. By this numerical technique, every derivative in the set of equations is directly replaced by an algebraic expression written at discrete points in space. This procedure first invokes the Fourier's equation (1) to obtain the heat flows from the known temperatures, and then the new temperatures using equation (2). During this second step the heat flows remain unchanged, thus the calculated temperatures do not affect them. This assumption is justified if the time step is small enough, i.e. smaller than a critical value taking care of

the requirements for numerical stability. The accuracy of the numerical solution is checked at each time step in comparing the balance of the internal energy with the heat transferred to the boundaries. The well known explicit method, perhaps the oldest numerical technique, is still very efficient in modeling nonlinear systems like the temperature development in setting concrete.

To model the heat transfer at the boundaries one-dimensional elements without any thermal inertia are used. This allows an adequate accuracy of the results quite independently from the dimension of the mesh used. As an example a comparison of two calculations is shown in **Figure 1**.

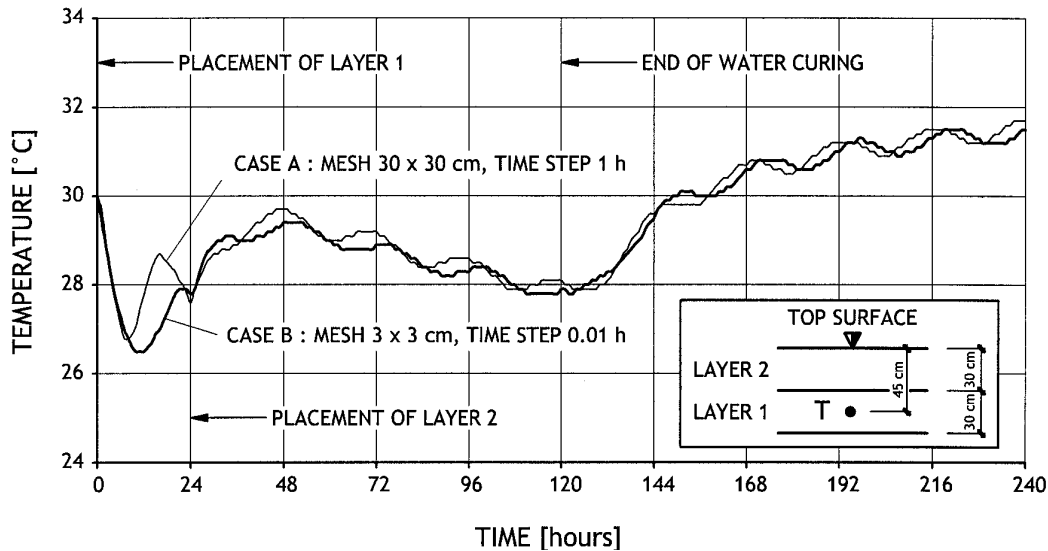

Fig. 1. Comparison of calculations with different mesh sizes (30 cm vs. 3 cm) Only a short time lag can be observed.

Case A was performed with a mesh of 30x30 cm and a time step of 1 h while Case B was performed with a mesh of 3x3 cm and a time step of 0.01 h. The figure shows the temperature development at the center of the first placed layer after placing two 0.3 m thick RCC layers, i.e. at 45 cm below the upper surface (at 15 cm during the first 24 h) by taking into account the hydration heat, the solar radiation, the water evaporation as well as the convection with a daily variation of the air temperature. A small difference, less than 1°C, is shown for short times, but the long term development is quite well simulated.

For the actual 2-D analysis a discretisation of 30 cm in the vertical and 33 cm in the horizontal direction was used. A time step of 1 h was chosen for updating the solar radiation even if the numerical stability could accept a longer one. The total number of calculation elements was 19'100 for the foundation rock and 35'700 for the concrete body.

3. BASIC DATA

3.1 CALCULATION MODEL

3.1.1 Dam geometry

The geometry of the block and the different concrete types are shown in **Figure 2**.

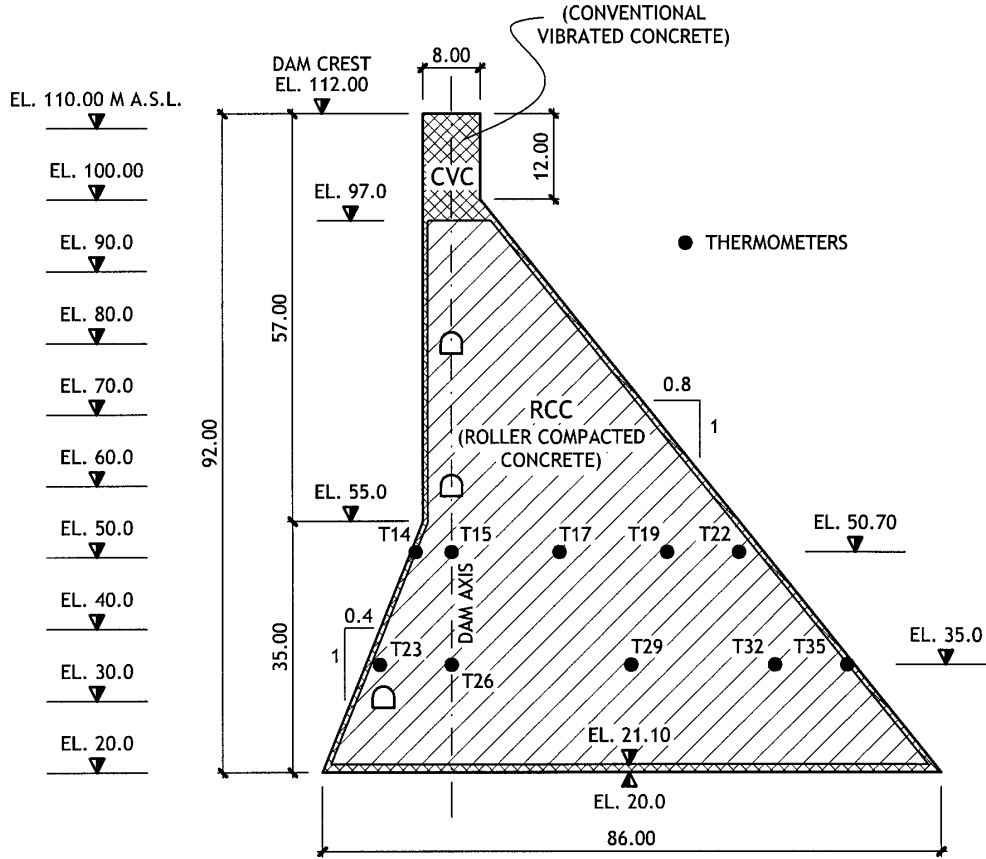

Fig. 2. Dam cross section and distribution of different concrete types.

The dam is mainly composed of RCC while both faces are made of conventional vibrated concrete CVC. The boundary surface between CVC at the dam faces and the RCC has the typical shape as a Christmas tree due to the placement method. In the simulation the thickness of the downstream as well as of the upstream face concrete was taken uniformly as 66 cm. The first layer on the rock as well as the crest section are made of CVC. For the CVC in the upper part no data were given by the formulator. For simulation purpose of the final dam some assumptions concerning the CVC had thus to be done, which may not correspond exactly to the real values.

Three inspection galleries are spared out at elevation 30, 60 and 80 m a.s.l. respectively. The temperatures of the RCC were measured during the construction at elevation 35.0 and 50.7 m a.s.l. by a total of 10 thermometers in order to allow a comparison of the measured and the computed temperatures.

The dam is placed on the foundation rock, which is modeled with a thickness of about 20 m. At the bottom and the sides of this bloc adiabatic conditions were assumed.

3.1.2 Construction procedure

The RCC is placed in 0.30 m thick layers. The top elevation of the placed lifts vs time is shown on **Figure 3**.

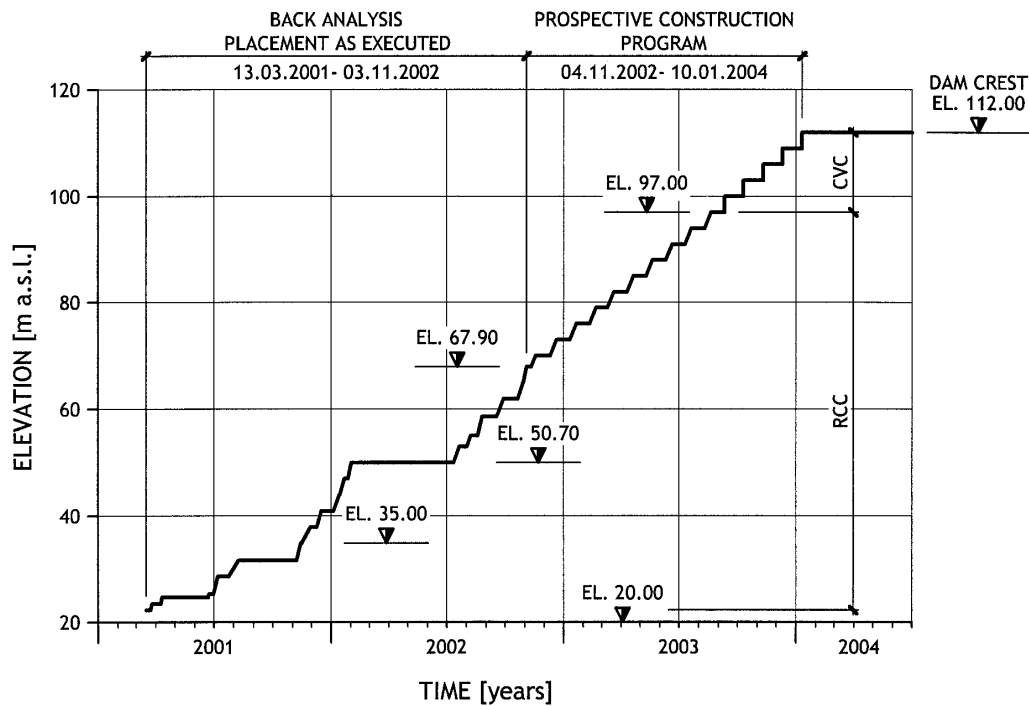

Fig. 3. Construction schedule.

Typically 10 layers are placed at a rate of about 1 layer per day, then a stoppage takes place during which the concrete is poured in other sections. The first part of the construction was simulated as to respect the actual placement date of each single lift until 3rd of September 2002. The second part of Figure 3 is a prospective construction program set up to simulate the completion of the 92 m high dam. The placement rate of the 30 cm thick layers corresponds to the steepest segments of the plot shown in this figure. The CVC at the top of dam is placed in 3 m thick layers.

3.2 CALCULATION PARAMETERS

3.2.1 Material properties

The parameters required to define the thermal behavior of the materials are summarized in **Table 1**.

Variable	Symbol	Unit	Rock	RCC	CVC
Unit weight	γ	kg/m ³	2'700	2'380	2'450
Specific heat	c	kJ/kg/°C	0.92	1.00	1.00
Conductivity	λ	W/m/°C	3.38	2.79	3.08

Tab. 1. Properties of the materials considered.

The cementitious material incorporated into the RCC is a mix of 100 kg Portland cement (STC) and 90 kg pouzzolanic fly ashes (PFA) per cubic meter of RCC. The hydration heat development of the mix was determined experimentally for the first week. The total heat generated corresponds to 265 J per gram cementitious material.

The CVC contains 350 kg/m³ of Portland cement. The hydration heat curve of the Portland cement was assumed to correspond to the one of the RCC binders multiplied by a factor of 1.25 since no direct measurements were available.

For both materials considered, the adiabatic temperature rise due to the cement hydration heat and its development with time is shown in **Figure 4**.

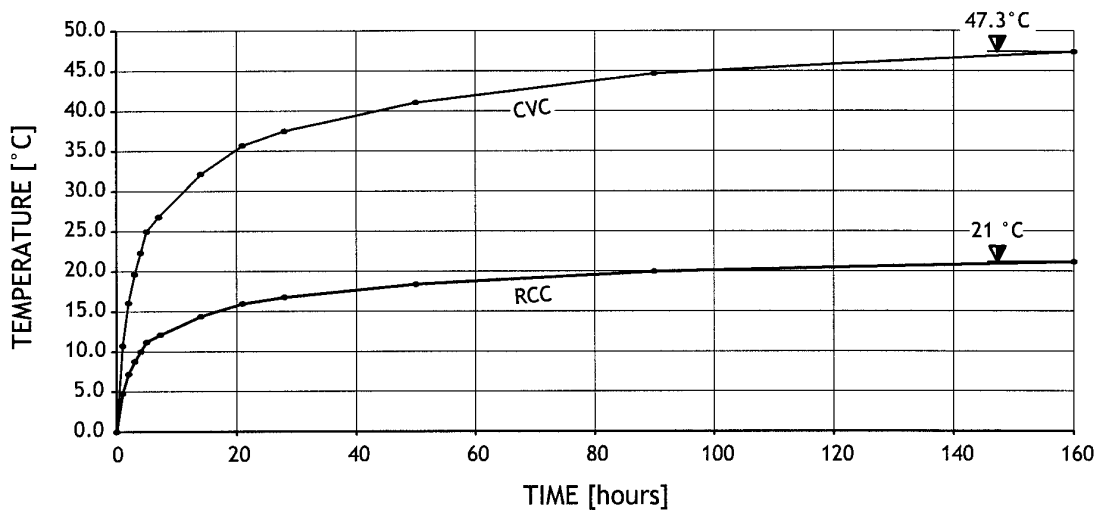

Fig. 4. Adiabatic temperature rise due to hydration heat.

3.2.2 Initial and boundary conditions

The ambient temperature at the site was measured close to both dam faces at irregular dates. The average value of the 88 readings made during a period of total about 13 month corresponds to 30°C. During two periods of a month a daily reading of the temperature was made: up to middle of November 2001, with an average temperature of 29°C, and up to middle of July 2002, with an average temperature of about 30°C. The annual variation of the air temperature is very small due to the location of the dam in a tropical country. It must however be pointed out that the influence of the solar radiation on the measurements is not clearly defined and that a single measurement per day does not procure any information about the daily variation. Therefore, since no further information is available, an arbitrary assumption had to be made. The air temperature follows thus a seasonal oscillation and a daily sinusoidal variation with a minimum at 6:00 AM and a maximum at 6:00 PM. **Table 2** summarizes the average temperatures assumed at mid-month, the daily variations as well as the average relative humidity. The tropical climate is characterized by typical springtime-summer monsoons, while the winter is dryer and slightly colder.

Month	Air temperatures [°C]		Relative humidity [%]
	Monthly average	Daily amplitude	
January	28.5	± 4.0	55
February	28.5	± 4.0	65
March	29.0	± 3.5	75
April	29.5	± 3.0	85
Mai	30.0	± 2.5	90
Juni	30.5	± 2.5	95
July	31.0	± 2.5	90
August	31.0	± 2.5	85
September	30.5	± 3.0	75
October	30.0	± 3.5	65
November	29.5	± 4.0	55
December	29.0	± 4.0	50

Tab. 2. Air temperature and relative humidity.

The following boundary conditions were assumed:

- The convection surface coefficient between concrete and air is $\alpha=35 \text{ W/m}^2/\text{°C}$.
- The reservoir water is not included in the present analysis.
- The maximal duration of the water curing on the upper surface is 5 days.
- The average wind speed is 1 m/s.
- For a height of 1.5 m below the lift top an insulation is placed on the lateral faces. The heat transfer of the insulated formwork is $\lambda/d=17 \text{ W/m}^2/\text{°C}$.
- The solar radiation is computed with the parameters listed below:
 - Geographical latitude of the dam (north hemisphere) 15 degrees
 - Orientation of the outward normal of the u/s face (north to east) 90 degrees
 - Average height of screen by mountains 5 degrees
 - Absorbivity of solar radiation by the concrete 0.60
 - Reduction factor for general nebulosity 0.65
 - Reduction factor for transmittance near horizon 0.60

In order to estimate the initial RCC temperatures, measurements have been carried out with the fresh concrete at the batching plant; additionally few (4) initial temperatures have been measured at the time of placement. These data seem to indicate that the temperature of the fresh RCC at this time is substantially higher than the one measured at the batching plant. The RCC temperature seems to correspond quite well to the temperature of the air at the same time. It was therefore decided to use the air temperature as initial RCC temperature. The layers at elevations 35.0 and 50.7 m a.s.l., which are equipped with thermometers to compare the measured and the computed temperatures, were thus supposed to having been placed at 30°C and 32°C respectively.

Finally, the temperature of the foundation rock at pouring the first concrete layer was computed along a previous period of 8 months, assuming an initial temperature of 30°C.

3. MAIN RESULTS

Figure 5 shows the temperature development at elevation 35.0 m a.s.l. after placing the layer, for different assumptions on the water curing of the upper surface. The air temperature and the adiabatic temperature development are also shown to ease the interpretation. The effect of both solar radiation and increasing temperature during the day can cause a temperature rise, which may exceed the adiabatic one. The figure illustrates as well the time of placing the next RCC layers and the increasing elevation of their top.

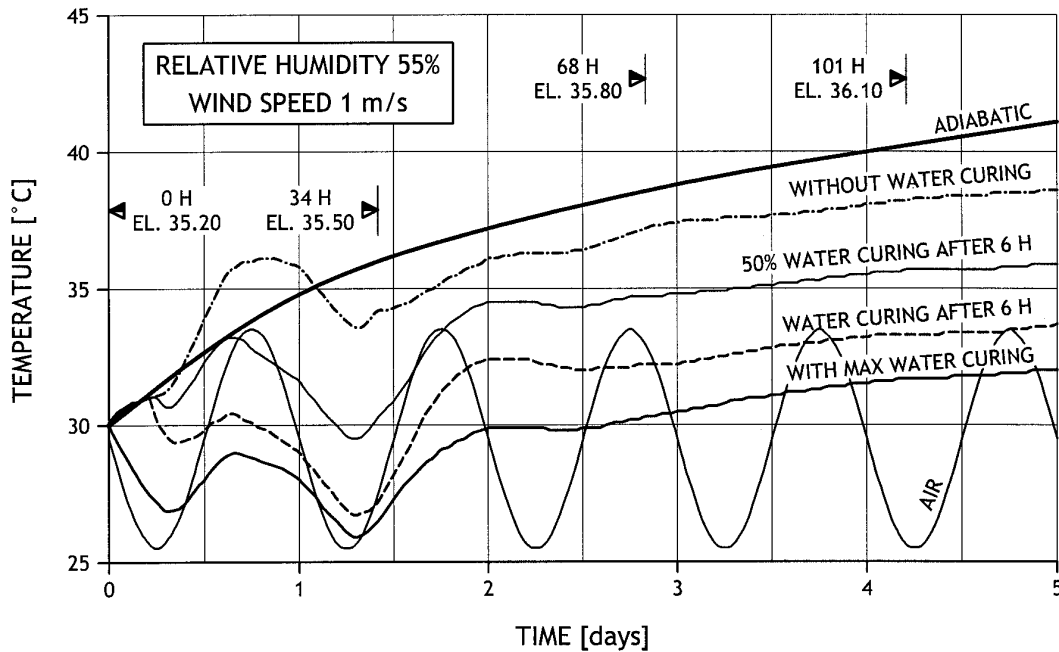

Fig. 5. Concrete temperature at elevation 35.0 m a.s.l. during setting at 55% relative humidity. (Month of November)

The water curing until placing the next layer (after 34 h) is of great importance. It can reduce the temperature by about 6-7°C from the case without water curing. This potentially maximal cooling is obtained when the curing starts immediately after placing the lift. In this case the amount of water sprayed must be measured very carefully, in order to avoid an excessive humidification of the concrete and a possible loss of strength. As a more practical case it was assumed that the water curing starts only 6 h after placing the RCC. At this time of maturity, the concrete should have reached a sufficient strength. In this case the reduction of the temperature is about 5°C.

By traditional concrete dams the effect of the curing is of less importance due to the fact that the concrete is placed in thick layers, while the effect of the water curing is limited to the top surface. Due to the low thickness of the RCC layers, most of the hydration heat, which develops during the first days, can be led away by the evaporation of water. Placing the concrete in thin layers allows to reduce the temperatures of each single lift and thus all along the entire dam height, while for conventional dams most of the concrete can't be reached by this positive effect.

During the construction of the dam the water curing might not occur systematically. So the last case shown on Figure 5 assumes that the water curing is only 50% effective, i.a. that at any time the evaporating water mass is only half of the potential one. This case is considered to be the most representative for the actual conditions at the site.

Logically, the effect of a water curing is reduced if the relative air humidity increases. **Figure 6** presents the temperature development at elevation 50.7 m a.s.l. for a relative air humidity of 90%. The difference between the cases with and without curing is reduced to 2°C at the best.

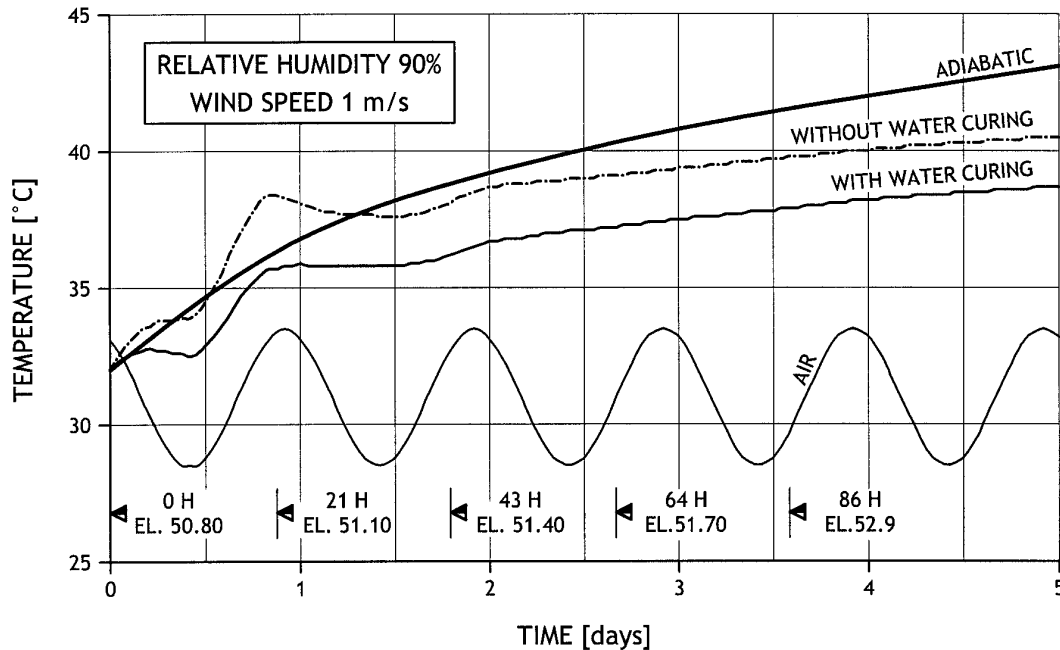

Fig. 6. Concrete temperature at elevation 50.7 m a.s.l. during setting at 90% relative humidity. (Month of July)

Figures 7 to 12 show the section of the dam during construction with the temperature field represented by isothermal lines at different dates and for the case of water curing activated at 50%.

Figure 7 refers to the temperature of the foundation rock before placing the first concrete layer. This initial condition is already the result of a preliminary calculation.

The thermal states of the dam during construction are presented in the Figures 8 to 11. The influence of a long stoppage in placing concrete can be observed as a local decrease in temperature vs elevation. So the temperature on 14.11.2001 (**Figure 8**) is influenced by the stoppage of 3 month at elevation 31.6 m a.s.l., while the temperature field on 10.08.2002 (**Figure 9**) is influenced by the stoppage of 5.5 month at elevation 49.9 m a.s.l.

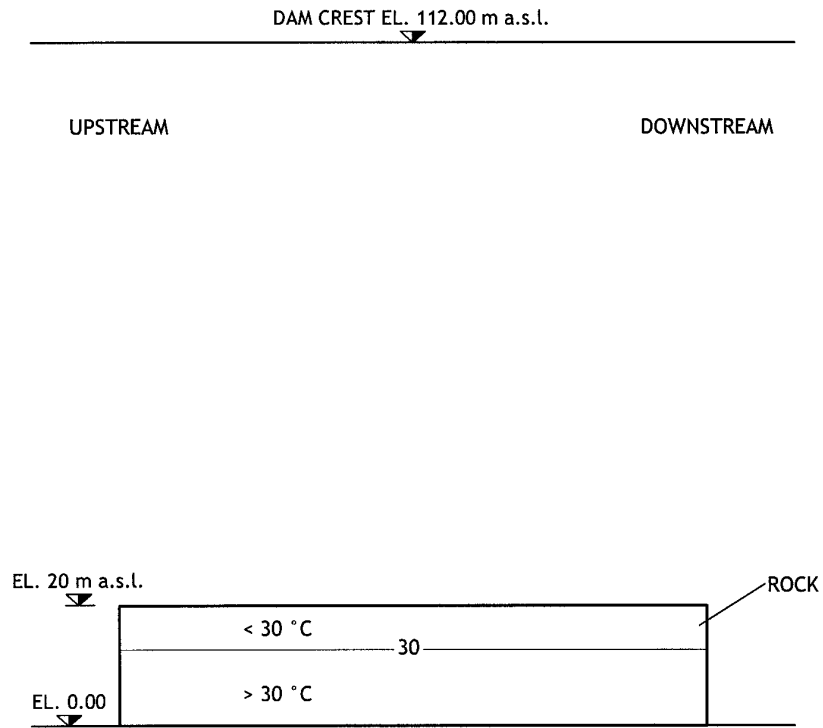

Fig. 7. Temperature in the foundation rock on 08.02.2001, before starting the construction of the dam.

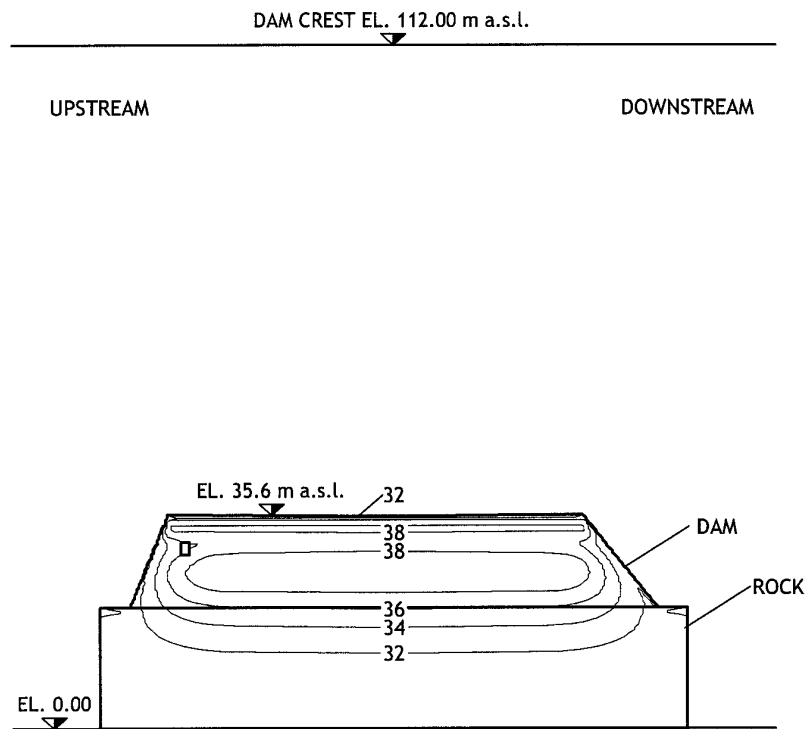

Fig. 8. Temperature in °C during construction on 14.11.2001 .

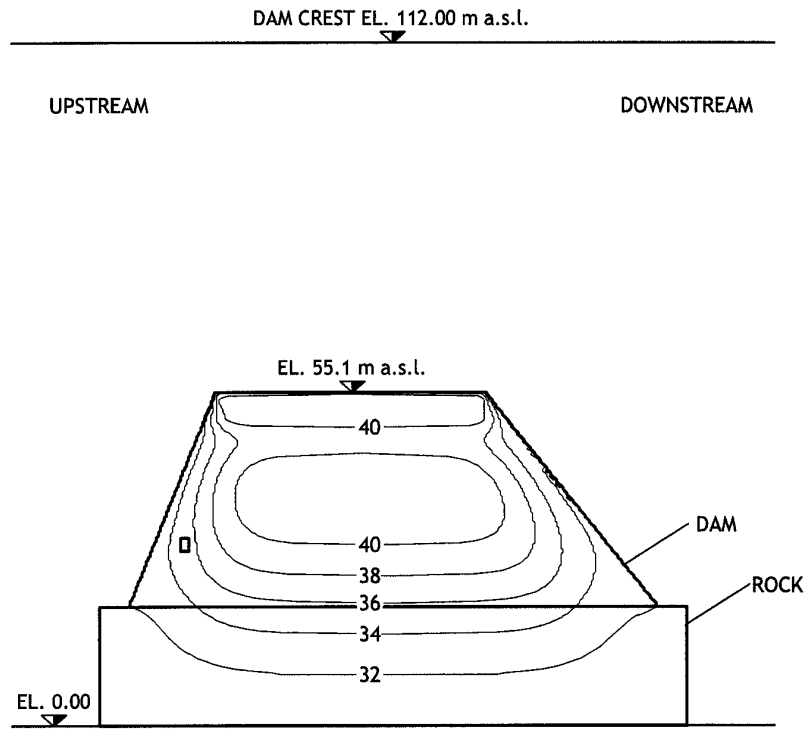

Fig. 9. Temperature in °C during construction on 10.08.2002 .

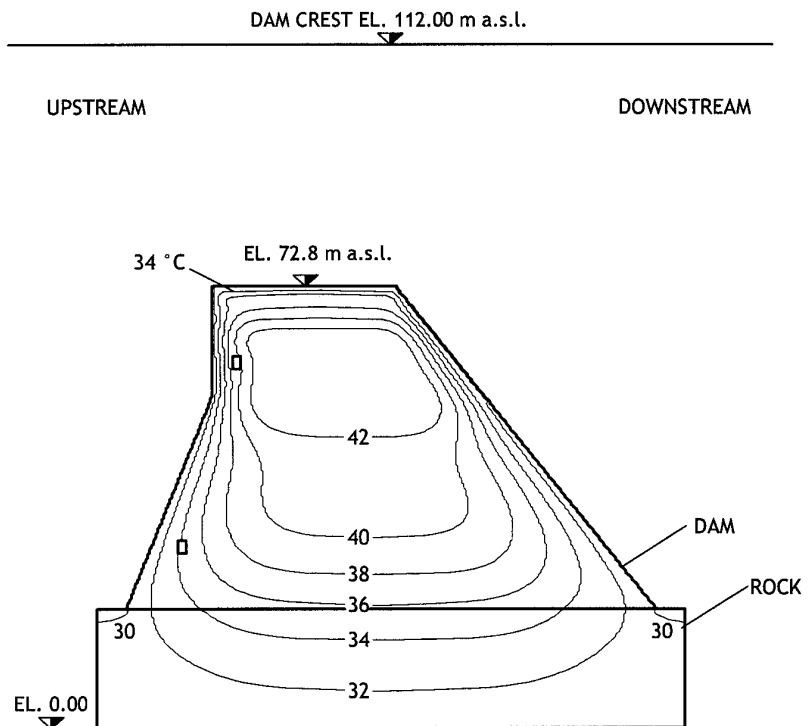

Fig. 10. Temperature in °C during construction on 28.12.2002 .

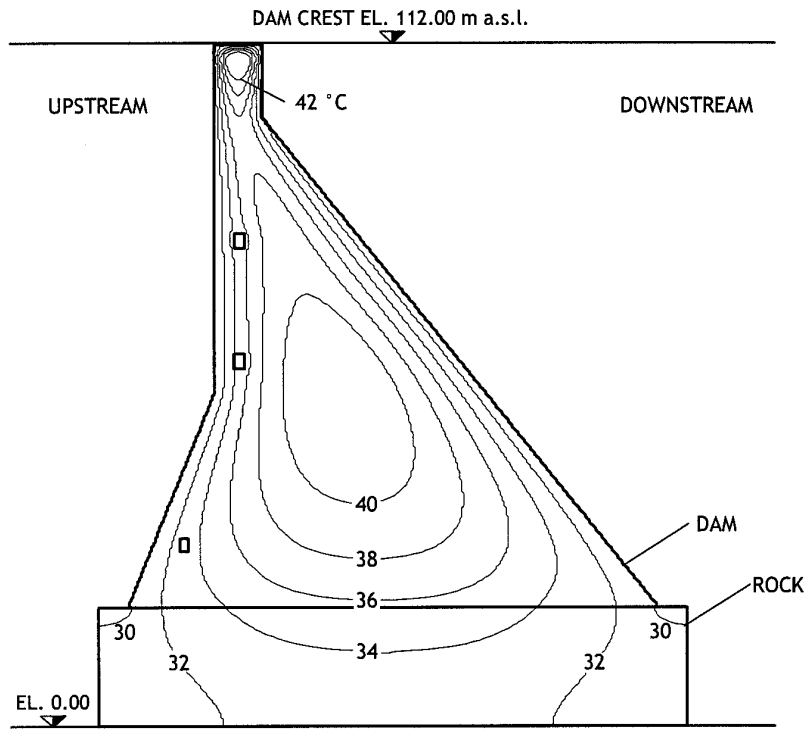

Fig. 11. Temperature in °C for the completed dam on 15.01.2004 .

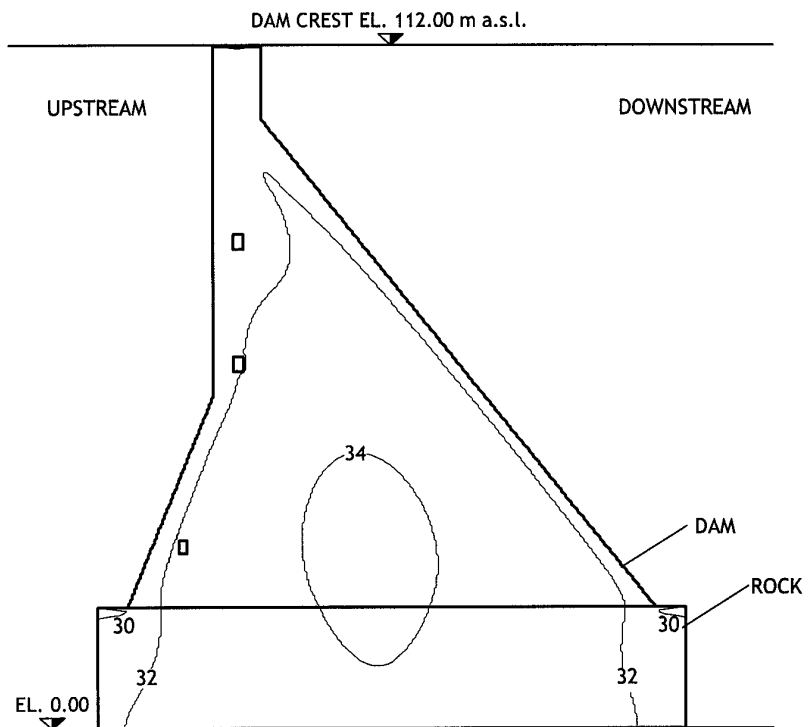

Fig. 12. Temperature in °C after several years (06.12.2010) .

Figure 10 shows the temperature field on 28.12.2002. Between elevations 50 and 65 a maximal temperature in the RCC is observed, which fact is due to the high average placing rate of about 1.75 days per layer during the warm and humid season of the year. A high temperature is reached also at the top of the dam as shown in **Figure 11**, where only CVC was used.

Figure 12 shows the temperature after approximately 7 years after completion. A residual hot zone is observed in the central part of the dam body. The raising of the pound level could not be considered, due to lacking information on the water management.

Figure 13 presents the long term history of the temperature in the center of the dam at four different elevations as well as the air temperature.

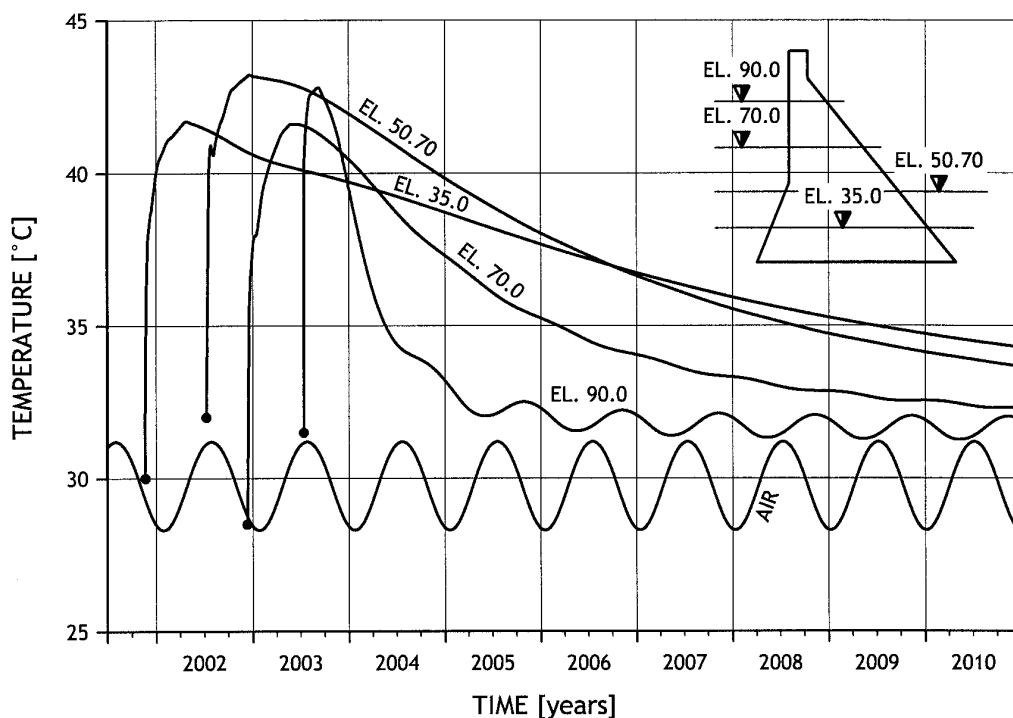

Fig. 13. History of the temperature at the center of 4 elevation .

The temperature at elevation 90.0 m a.s.l. reaches already after 4 years a final equilibrium, while at the other elevations the hydration heat needs more than 9 years to be almost completely led away. It may be noticed that the final average temperature at elevation 90.0 m a.s.l. is still 1.9-2.0°C higher than the air temperature because of the solar radiation. At elevation 35.0 m a.s.l. a residual of the temperature rise of about 2.5°C at the central point may still be observed 9 years after placing the lift. The maximal temperature of 43°C is reached at elevation 50.7 m a.s.l., which corresponds to a temperature increase of 11°C due to the hydration heat. It must be pointed out that an adiabatic temperature would have reached a temperature peak of 53°C.

The maximal difference between the internal and the air temperature is about 15°C. This value can be considered acceptable for RCC dams in matters of thermal cracking. For conventional dams a maximal value of 20°C is generally considered as a

limit for practical reasons since the calculation of the stresses in the concrete during hardening is very uncertain.

4. CONCLUSIONS

The present paper reports on a thermal study of a 92 m high RCC dam during and after construction. The following conclusions may be stated:

- For RCC dams the temperature of each thin layer after its placement can be significantly reduced by the water evaporating on the upper face. For conventional dams, this phenomenon is of lesser importance due to the greater thickness of the layers and because of the limited extension in space of its influence. The final result for RCC dams is comparable to a pre-cooling of the fresh concrete.
- RCC dams are hardly subjected to thermal cracking if the external temperature is more or less constant, as in tropical climate, and the initial concrete temperature is not very different of that of the air.
- Obviously, by significant seasonal variations, cracks may appear at the faces of a thick RCC gravity dam during the following winter if the placing occurred at summer time. The cracking is caused by the temperature increase in the interior of the dam combined with the fast cooling of the surface in winter. For this reason a post-cooling with pipes was proposed for the Three Gorges Dam [3].
- The temperature of the core of a thick gravity dam requires a long time to drop to the final equilibrium state (more than 9 years in this case).

To conclude, it may be stated that the main difficulty of the presented exercise - and in general of thermal calculations- consists in the correct determination of the parameters to be used. The thermal behavior during setting is a very complicated process, which involves many uncertainties in both material properties and environmental conditions. An error of 20-30% can thus be considered as an excellent accuracy for the analysis of practical problems [4]. The main source of errors are due rather to the input data than to the modeling or computation techniques, because many key parameters and material properties vary in quite wide ranges.

REFERENCES

- [1] Mondada, A. – Adaptation au cours des travaux du projet du système de refroidissement au barrage de Zimapán, CNSGB Symposium de Crans-Montana, Septembre 1995
- [2] Recknagel, H., Sprenger, E. – Taschenbuch für Heizung und Klimatechnik, R. Oldenbourg Verlag München, 61. Auflage 1981
- [3] Bofang, Z., Ping, Xu – Thermal Stresses in Roller Compacted Gravity Dams, Dam Engineering, Vol. VI, Issue 3, 1995
- [4] Wang, Ch., Dilger, W.H. – Prediction of temperature distribution in hardening concrete, International RILEM Symposium of Munich, October 1994